

THOMSON



tv.mythomson.com



[tv.mythomson.com/
en/Support/FAQs/](https://tv.mythomson.com/en/Support/FAQs/)



[tv.mythomson.com/
Support/Product-Registration/](https://tv.mythomson.com/Support/Product-Registration/)

FIRE TV

IMPORTANT

Please read this manual carefully before installing and operating the TV.
Keep this manual handy for further reference.

Contents

1	Safety Information	8
1.1	Markings on the product.....	9
1.2	Warning.....	9
1.3	Wall mounting warnings.....	10
1.4	Simplified EU declaration of conformity.....	11
1.5	Apps and performance.....	11
1.6	Data protection	11
2	Introduction and feet installation.....	11
2.1	Accessories Included	12
2.2	Unpacking	12
2.3	Assembling the feet.....	12
2.4	Wall mount bracket.....	13
2.5	Removing the stand from the TV	13
3	TV buttons and connections.....	14
3.1	TV button.....	14
3.2	Connections.....	15
4	Remote Control.....	16
4.1	Inserting the Batteries into the Remote.....	17
4.2	To pair remote with the TV	17
5	Turning On/Off the TV	17
6	TV Control & Operation.....	18
6.1	Operating with the Control Button.....	18
6.2	Operation with the Remote Control.....	19
6.3	Input Selection.....	19
6.4	Changing Channels and Volume	19
7	Initial Setup Wizard.....	20
7.1	Choose Your Location	20

7.2	Choose Your Language.....	20
7.3	Select TV Mode	20
7.4	Pair Your Remote with your TV.....	20
7.5	Connect to your network.....	20
7.6	Sign In with Your Amazon Account	21
7.7	Restore Fire TV.....	21
7.8	Parental Controls	21
7.9	Prime Video	22
7.10	Welcome to Fire TV.....	22
7.11	Scan for TV channels.....	22
7.12	Channel Type.....	22
8	Home Screen.....	23
9	Live TV	24
10	Customizing TV Settings.....	24
10.1	Picture Settings.....	24
10.2	Picture Menu Content.....	25
10.3	Audio Settings	26
10.4	Audio Menu Content.....	26
11	Settings.....	27
12	Inputs	27
12.1	Accessing the Inputs Menu.....	27
12.2	Selecting an Input.....	27
12.3	Changing an Inputs Name	28
12.4	Media Player.....	28
13	Notifications	29
13.1	Reading Notifications.....	29
13.2	Clearing Notifications	29
13.3	Managing Notifications.....	29
13.4	Notification Settings.....	29
14	Account & Profile	30
14.1	Amazon Account.....	30
14.2	Sync Amazon Content	30

14.3	Prime Video	30
14.4	Parental Controls	30
14.5	Profiles	31
14.6	Profile Sharing.....	31
15	Network.....	31
15.1	Checking Network Status	31
15.2	Seeing All Networks.....	32
15.3	Joining a Network Using the WPS Button or PIN.....	32
15.4	Advanced Network Settings.....	32
15.5	Saving your WLAN Password to your Amazon Account	32
15.6	Turning on your TV via LAN and WLAN.....	32
15.7	Changing Connection Status.....	33
15.8	Basic Wi-Fi Troubleshooting Tips	33
16	Display & Audio	33
16.1	Picture Settings.....	33
16.2	Sound Settings	33
16.3	Apple AirPlay & HomeKit	33
16.4	Power Controls	34
16.5	Audio Output	34
16.6	Live TV Language Preferences.....	34
16.7	Enable Display Mirroring	34
16.8	Navigation Sounds.....	35
16.9	Screen Saver	35
16.10	HDMI-CEC Device Control	35
17	Applications	36
17.1	Amazon Photo Settings.....	36
17.2	Saving Gaming Progress.....	36
17.3	App Store.....	36
17.4	Manage Installed Applications	37
18	Downloading and Organizing Applications	37
18.1	Downloading Apps	37
18.2	Organizing Apps on the Home Screen.....	37

19	Equipment Control.....	38
19.1	Adding a Soundbar or Audio Receiver.....	38
19.2	Soundbar/Audio Receiver Settings.....	39
20	Live TV.....	39
20.1	Tuning in your TV.....	39
20.2	Automatic Service Update.....	40
20.3	Favorite Channels.....	40
20.4	Manage Channels.....	40
20.5	CI Card.....	41
20.6	Parental Controls.....	41
20.7	Sync Sources.....	42
20.8	HbbTV.....	42
21	Remotes & Bluetooth Devices.....	42
21.1	Add or View Status of Remote Controls with Alexa.....	42
21.1.1	View Remote Status.....	42
21.1.2	Add New Remote.....	42
21.2	Adding a Bluetooth Game Controller.....	43
21.3	Adding a Bluetooth Device.....	43
22	Alexa.....	43
22.1	Alexa App.....	43
22.2	Things to Try.....	43
23	Preferences.....	44
23.1	Parental Controls.....	44
23.2	Privacy Settings.....	44
23.3	Data Monitoring.....	45
23.4	Notification Settings.....	45
23.5	Featured Content.....	45
23.6	Auto Turn Off.....	46
23.7	HbbTV.....	46
23.8	Time Zone.....	46
23.9	Sync Date and Time.....	46
23.10	Language.....	46

23.11	Metric Units.....	46
24	Sleep Timer	47
25	Device & Software.....	47
25.1	About.....	47
25.2	Developer Options.....	47
25.3	Legal & Compliance	48
25.4	Sleep.....	48
25.5	Restart.....	48
25.6	Reset to Factory Defaults.....	48
26	Accessibility.....	48
26.1	Subtitle.....	48
26.2	Alexa Subtitle	48
26.3	VoiceView	49
26.4	Text Banner.....	49
26.5	Screen Magnifier.....	49
26.6	High-Contrast Text	49
26.7	Audio Description.....	49
26.8	Spoken Subtitles for Broadcast Channels.....	49
27	Help.....	50
27.1	Help Videos.....	50
27.2	Quick Tips.....	50
27.3	Contact Us.....	50
27.4	Feedback.....	50
28	Channel List.....	50
29	Channel Guide	51
29.1	Highlight & Filter	51
29.2	Scrolling Forwards or Backwards Through the Guide Day by Day	51
29.3	On Screen Mini Guide.....	51
30	Connecting to the Internet	52
30.1	Wired Connection.....	52
30.2	Wireless Connection.....	53
31	Troubleshooting	55

32 Technical specifications 57

 32.1 Country Restrictions 58

33 License 58

1 Safety Information



In extreme weather (storms, lightning) and long inactivity periods (going on holiday) disconnect the TV set from the mains.

The mains plug is used to disconnect the TV set from the mains and therefore it must remain readily operable. If the TV set is not disconnected electrically from the mains, the device will still draw power for all situations even if the TV is in standby mode or switched off.

Note: Follow the onscreen instructions for operating the related features.

Important: Please read these instructions fully before installing or operating the TV.

WARNING

This device is intended to be used by persons (including children) who are capable / experienced of operating such a device unsupervised, unless they have been given supervision or instruction concerning the use of the device by a person responsible for their safety.



- Use this TV set at an altitude of less than 5000 meters above the sea level, in dry locations and in regions with moderate or tropical climates.
- The TV set is intended for household and similar indoor use but may also be used in public places.
- For ventilation purposes, leave at least 5cm of free space around the TV.
- The ventilation should not be impeded by covering or blocking the ventilation openings with items, such as newspapers, tablecloths, curtains, etc.
- The power cord/plug should be easily accessible. Do not place the TV, furniture, etc. on the power cord. A damaged power cord/plug can cause fire or give you an electric shock. Handle the power cord by the plug, do not unplug the TV by pulling the power cord. Never touch the power cord/plug with wet hands as this could cause a short circuit or electric shock. Never make a knot in the power cord or tie it with other cords. When damaged it must be replaced, this should only be done by qualified personnel.
- Do not expose the TV to dripping or splashing of liquids and do not place objects filled with liquids, such as vases, cups, etc. on or over the TV (e.g. on shelves above the unit).
- Do not expose the TV to direct sunlight or do not place open flames such as lit candles on the top of or near the TV.
- Do not place any heat sources such as electric heaters, radiators, etc. near the TV set.
- Do not place the TV on the floor or inclined surfaces.
- To avoid danger of suffocation, keep plastic bags out of the reach of babies, children and domestic animals.
- Carefully attach the feet to the TV. If the feet are provided with screws, tighten the screws firmly to prevent the TV from tilting. Do not over-tighten the screws and mount the stand rubbers properly.
- Do not dispose of the batteries in fire or with hazardous or flammable materials.

- Do not use household cleaning agents to clean the TV. Instead clean the screen with a soft, dry cloth. Before cleaning, unplug the device for safety.

WARNING

- Batteries must not be exposed to excessive heat such as sunshine, fire or the like.
- Excessive sound pressure from earphones or headphones can cause hearing loss.

ABOVE ALL - NEVER let anyone, especially children, push or hit the screen, push anything into holes, slots or any other openings in the TV.

 Caution	Serious injury or death risk
 Risk of electric shock	Dangerous voltage risk
 Maintenance	Important maintenance component

1.1 Markings on the product

The following symbols are used on the product as a marker for restrictions and precautions and safety instructions. Each explanation shall be considered where the product bears related marking only. Note such information for security reasons.



Class II Equipment: This appliance is designed in such a way that it does not require a safety connection to electrical earthing.



This marking indicates that this product should not be disposed with other household wastes throughout the EU. Please recycle it responsibly to promote the sustainable reuse of material resources. To return your used device, please use the return and collection systems or contact the retailer where the product was purchased.



Hazardous Live Terminal: The marked terminal(s) is/are hazardous live under normal operating conditions.



Caution, See Operating Instructions: The marked area(s) contain(s) user replaceable coin or button cell batteries.



Class 1 Laser Product: This product contains a Class 1 laser source that is safe under reasonably foreseeable conditions of operation.

1.2 Warning

- Do not ingest the battery, Chemical Burn Hazard.

- This product or the accessories supplied with the product may contain a coin/button cell battery. If the coin/ button cell battery is swallowed, it can cause severe internal burns in just 2 hours and can lead to death.
- Keep new and used batteries away from children.
- If the battery compartment does not close securely, stop using the product and keep it away from children.
- If you think batteries might have been swallowed or placed inside any part of the body, seek immediate medical attention.

A television may fall, causing serious personal injury or death. Many injuries, particularly to children, can be avoided by taking simple precautions such as:

- ALWAYS use cabinets or stands or mounting methods recommended by the manufacturer of the television set.
- ALWAYS use furniture that can safely support the television set.
- ALWAYS ensure the television set is not overhanging the edge of the supporting furniture.
- ALWAYS educate children about the dangers of climbing on furniture to reach the television set or its controls.
- ALWAYS route cords and cables connected to your television so they cannot be tripped over, pulled or grabbed.
- NEVER place a television set in an unstable location.
- NEVER place the television set on tall furniture (for example, cupboards or bookcases) without anchoring both the furniture and the television set to a suitable support.
- NEVER place the television set on cloth or other materials that may be located between the television set and supporting furniture.
- NEVER place items that might tempt children to climb, such as toys and remote controls, on top of the television or furniture on which the television is placed on.
- The equipment is only suitable for mounting at heights ≤ 2 m.

If the existing television set is going to be retained and relocated, the same considerations as above should be applied.

Apparatus connected to the protective earthing of the building installation through the mains connection or through other apparatus with a connection to protective earthing – and to a television distribution system using coaxial cable, may in some circumstances create a fire hazard. Connection to a television distribution system has therefore to be provided through a device providing electrical isolation below a certain frequency range (galvanic isolator).

1.3 Wall mounting warnings

- Read the instructions before mounting your TV on the wall.
- The wall mount kit is optional. You can obtain it from your local dealer if it is not supplied with your TV.

- Do not install the TV on the ceiling or on an inclined wall.
- Use the specified wall mounting screws and other accessories.
- Tighten the wall mounting screws firmly to prevent the TV from falling. Do not overtighten the screws.

Figures and illustrations in this user manual are provided for reference only and may differ from the actual product appearance. Product design and specifications may be changed without notice.

Because the Fire TV operating system is periodically updated, the images, navigation instructions, titles and location of menu options shown in this manual may be different from what you see on the screen.

1.4 Simplified EU declaration of conformity

Hereby, StreamView GmbH declares that the radio equipment type product device Amazon Fire TV is complying with Directive 2014/53/EU.

1.5 Apps and performance

Download speed is dependent on your internet connection. Some apps may not be available in your country or region. Netflix is available in select countries:

<https://help.netflix.com/node/14164>.

A streaming membership is required. More information is available at www.netflix.com. The availability of supported languages for Alexa depends on the region where the device was purchased.

1.6 Data protection

Application providers and service providers may collect and use technical data and related information, including but not limited to technical details about this device, its system, application software, and peripherals. This information may be used to improve their products or provide services and technologies that do not personally identify you. Additionally, some third-party services, either pre-installed on the device or installed by you after purchase, may require registration with your personal data. Some services may collect personal data without providing additional warnings. StreamView GmbH cannot be held liable for any potential breaches of data protection by third-party services.

2 Introduction and feet installation

Thank you for choosing our product. You'll soon be enjoying your new TV. Please read these instructions carefully. They contain important information which will help you get the best from your TV and ensure safe and correct installation and operation.

2.1 Accessories Included

- Voice Remote with Alexa
- Batteries: 2 x AAA
- Power Cord

2.2 Unpacking

Take out the feet and the TV from the packing case and put the TV onto a work table with the screen panel down on a clean and soft cloth (blanket, etc.)

- Use a flat and firm table or similar even surface that can support the weight of the TV.
- Do not hold the TV on the screen panel.
- Make sure not to scratch or break the TV.

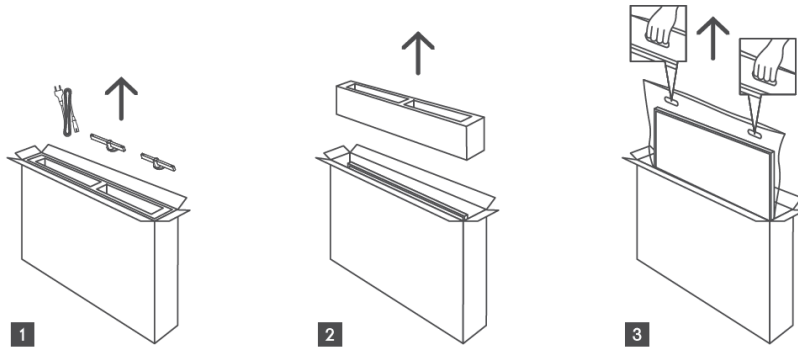

2.3 Assembling the feet

The feet of the TV can be attached to the bottom of the unit using either one or two screws, depending on the screen size. For 32-inch models, one screw per foot is sufficient, while 40-inch models require two screws per foot for added stability. This ensures the feet are properly aligned and provide optimal support based on the size of the TV. Be sure to follow the instructions in the user manual to ensure proper installation.

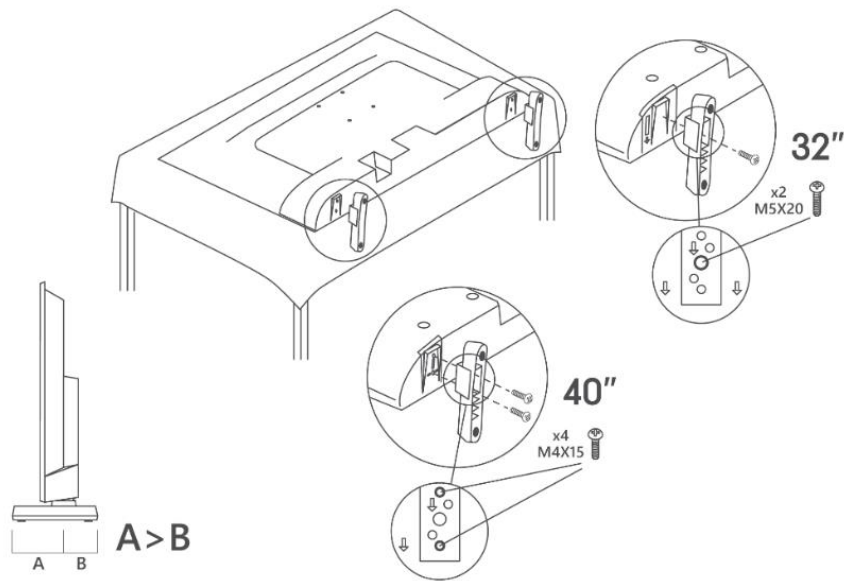

2.4 Wall mount bracket

Your TV is prepared for a VESA-compliant wall mount bracket. This is not supplied with your TV. Contact your local dealer to purchase the recommended wall mount bracket.

Holes and measurements for wall mount bracket installation:

	W (mm)	H (mm)	D (mm)	L _A (mm)	L _B (mm)
32"	75	75	4 (M4)	7-10	5-6
40"	100	100	4 (M4)	7-10	5-6

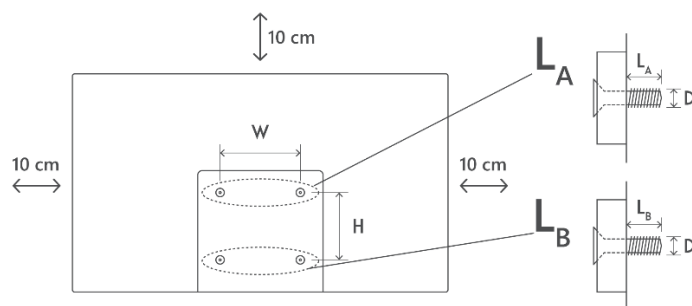

2.5 Removing the stand from the TV

Be sure to remove the stand in the following way when using the wall-hanging bracket or repacking the TV.

- Put the TV onto a work table with the screen panel down on the clean and soft cloth. Leave the feet protruding over the edge of the surface.

- Unscrew the screws that hold the feet in place.
- Remove the feet.

3 TV buttons and connections

Caution:



If you want to connect a device to the TV, make sure that both the TV and the device are turned off before making any connection. After the connection is done, you can turn on the units and use them.



Do not touch or be close to the HDMI, USB terminals, and prevent electrostatic discharge from disturbing these terminals while in USB operation mode, or it will cause the TV to stop working or cause an abnormal status.

Note:

The actual position and arrangement of ports may be different from model to model.

3.1 TV button

The exact appearance of the TV, including logo placement and frame, differs by TV model. Please use these illustrations as reference only.

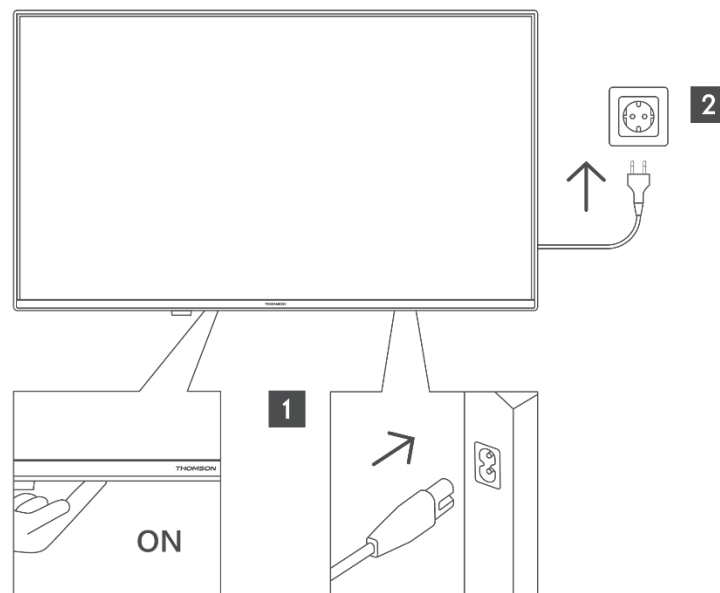

Press this button in standby mode to turn on / off the TV.

3.2 Connections





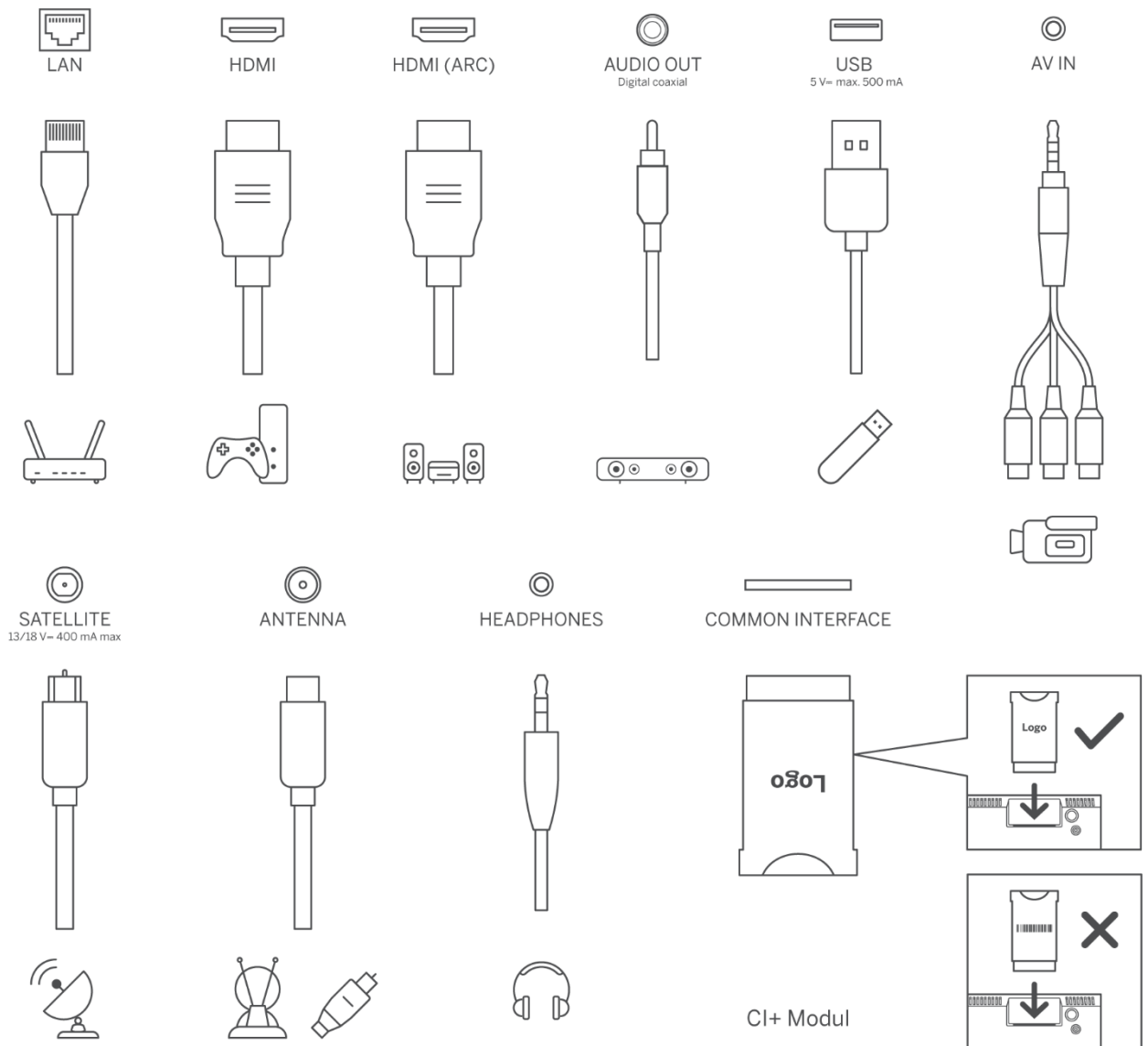













If you want to connect a device to the TV, make sure that both the TV and the device are turned off before making any connection. After the connection is done, you can turn on the units and use them.

When using the wall mounting kit (contact your dealer to purchase one, if not supplied), we recommend that you plug all your cables into the back of the TV before mounting on the wall. Insert or remove the CI module only when the TV is SWITCHED OFF. You should refer to the module instruction manual for details of the settings. The USB inputs on the TV support devices up to 500mA. Connecting devices that have current value above 500 mA may damage your TV. When connecting equipment using a HDMI cable to your TV, to guarantee sufficient immunity against parasitic frequency radiation and trouble-free transmission of high-definition signals, such as 4K content, you have to use a high speed shielded (high grade) HDMI cable with ferrites.



4 Remote Control



	Standby: On/OFF
	Microphone opening: Speak into the microphone when using Alexa or voice search.
	Voice button: Activate the microphone on the remote and Alexa on the TV
	Directional buttons: Navigate menus, setting options, move the focus or cursor etc. Follow the on-screen instructions.
	OK: Confirm selection, enter sub-menus
	Back: Return to the previous menu screen, go one step back, close windows, close teletext (in Live TV-Teletext mode), return to main screen or Home tab
	Home: Open the Home screen. Press and hold to display quick settings menu
	Options: Display setting options (where available)
	Rewind: Move frames backwards in media such as movies, scroll back a day in the channel guide
	Play/Pause Pause: Pause the media being played Play: Start to play selected media
	Fast forward: Move frames forward in media such as movies, scroll forward a day in the channel guide
	Volume +/-: Increase/decrease the volume level
GUIDE	Guide: Display the channel guide
	Mute: Completely turn off the volume of the TV
	Program +/-: Increase/Decrease channel number in Live TV mode
0-9	Numeric buttons: Switch the channel in Live TV mode, enter a number in the text box on the screen
SUBT	Subtitle: Display audio and subtitle options, where you can change the language, size and style preference (where available)
TXT	Text: Open and close teletext or interactive services (where available in Live TV mode)
	Prime Video: Launch the Prime Video application
	Netflix: Launch the Netflix application
	Internet: Launch the Amazon Silk internet browser application
	Apps: Display your apps & channels
	Colored Buttons: Follow the on-screen instructions for colored button functions

4.1 Inserting the Batteries into the Remote

Remove the back cover to reveal the battery compartment on the back side of the remote control first. Insert two 1.5V size AAA batteries. Make sure the (+) and (-) signs match (check correct polarity). Do not mix old and new batteries. Replace only with the same or equivalent type. Place the cover back on.

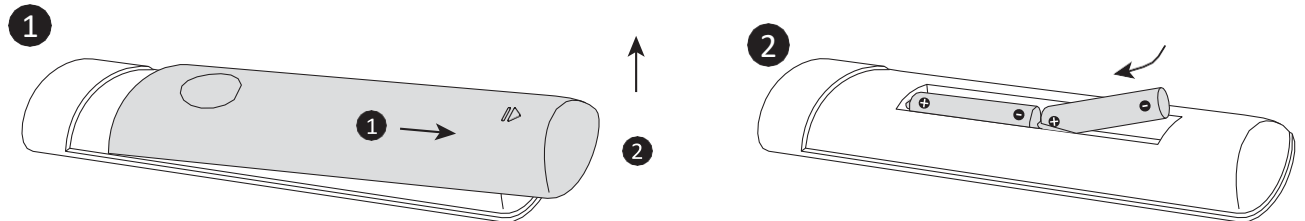

4.2 To pair remote with the TV

When the TV is turned on for the first time, a pairing process for your remote will be performed during the initial setup. Your remote control should automatically pair with your TV at this point, but if it didn't, follow the on-screen instructions to pair it. If you experience difficulties pairing your remote with your TV, turn off other wireless devices and try again. Refer to the Remotes & Bluetooth Devices section for detailed information on pairing new devices with your TV.

5 Turning On/Off the TV

Connect power

IMPORTANT: The TV set is designed to operate on 220-240 V AC, 50 Hz socket.

After unpacking, allow the TV set to reach the ambient room temperature before you connect the set to the mains.

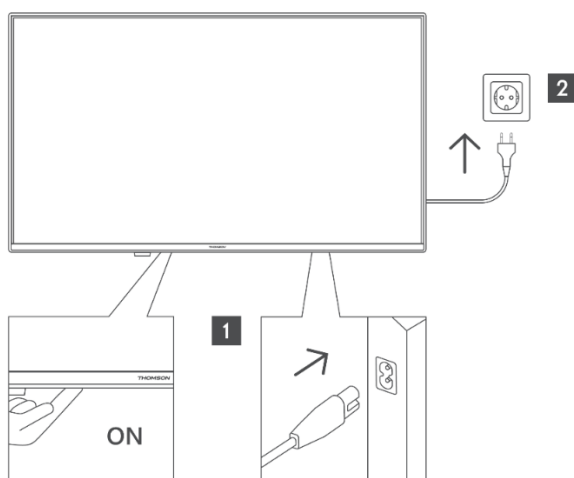

Plug one end (the two-hole plug) of the supplied detachable power cord into the power cord inlet on the rear side of the TV as shown above. Then plug the other end of the power cord into the mains socket outlet. The TV will switch to standby mode.

Note: The position of the power cord inlet may differ depending on the model.

To switch on the TV from standby

If the TV is in standby mode the standby LED lights up. To switch on the TV from standby mode either:

- Press the **Standby** button on the remote control.
- Press the control button on the TV. The TV will switch on.

To switch the TV into standby

- Press the **Standby** button on the remote control.
- Press the control button on the TV, the function options menu will be displayed. The focus will be on the 'Inputs' option. Press the button consecutively until the 'Power Off' option is highlighted. Press and hold the button for about 2 seconds, the TV will switch into standby mode.

To switch off the TV

To power down the TV completely, unplug the power cord from the mains socket.

6 TV Control & Operation

Your TV has a single control button. This button allows you to control the Inputs / Volume Up-Down / Channel Up-Down / Standby-On functions of the TV.

6.1 Operating with the Control Button

- Press the control button to display the function options menu.
- Then press the button consecutively to move the focus to the desired option if needed.
- Press and hold the button for about 2 seconds to use the function, enter the sub menu or select the option.

To turn off the TV

Press the control button to display the function options menu, the focus will be on the 'Inputs' option. Press the button consecutively until the 'Power Off' option is highlighted. Press and hold the button for about 2 seconds to turn the TV off (standby mode).

To turn on the TV

Press the control button, the TV will turn on.

To change volume

Press the control button to display the function options menu and then press the button consecutively to move the focus to the 'Volume Up' or 'Volume Down' option. Press and hold the button to increase or decrease the volume.

To change channel (in Live TV mode)

Press the control button to display the function options menu and then press the button consecutively to move the focus to 'Channel Up' or 'Channel Down' option. Press and hold the button to switch to the next or previous channel in the channel list.

To change input

Press the control button to display the function options menu, the focus will be on the Inputs option. Press and hold the button for about 2 seconds to display the inputs list. Scroll through the available input options by pressing the button. Press and hold the button for about 2 seconds to switch to the highlighted input option.

Note: The Live TV settings menu OSD in Live TV mode cannot be displayed via the control button.

6.2 Operation with the Remote Control

Press and hold the **Home** button on your remote control to display available quick settings menu options when in Live TV mode. Press the **Home** button to display or return to the Home screen of your TV. Use the directional buttons to move the focus, proceed, adjust some settings and press **OK** to make selections in order to make changes, set your preferences, enter a sub-menu, launch an application etc. Press **Back** to return to the previous menu screen.

6.3 Input Selection

Once you have connected external systems to your TV, you can switch to different input sources. Press and hold the **Home** button on your remote control to display available quick settings menu options. Then highlight the 'Inputs' option and press the **OK** button to display the list of available input options. Use the directional buttons to highlight the option of your choice and then press the **OK** button to switch to the selected input. Or select the desired input from the 'Inputs' row in the Inputs tab on the Home screen and press **OK**.

6.4 Changing Channels and Volume

You can adjust the volume by using the Volume +/- buttons and change the channel in Live TV mode by using the Program up/down buttons on the remote.

7 Initial Setup Wizard

Note: Follow the on-screen instructions to complete the initial setup process. Use the directional buttons and the **OK** button on the remote to select, set, confirm and proceed.

7.1 Choose Your Location

Select your Location from the list and press **OK** to continue.

7.2 Choose Your Language

The language selection options will be listed on the screen. Select the desired language from the list and press **OK** to continue.

7.3 Select TV Mode

In the following step of the initial setup, you can set the TV's operation mode. The 'Store Use' option will configure your TV's settings for a store environment. This option is intended only for store use. It is recommended to select **Continue** for 'Home Use'.

7.4 Pair Your Remote with your TV

If your remote control pairs with your TV automatically or if you have paired your remote with your TV previously, this step will be skipped. If this is not the case, a search for your remote will be performed. Follow the on-screen instructions to pair your remote control (the specific steps depend on the model of the remote control).

7.5 Connect to your network

The network connection is not available automatically, even if you connected your TV to the internet via an Ethernet cable before the initial setup started. The connection option has to be enabled first. In this installation step a confirmation dialogue will be displayed on the screen. You will be informed that the power consumption may increase and be asked for your consent to continue. Highlight **Enable** and press **OK** to proceed.

If you did not connect your TV to the internet via an Ethernet cable, your TV will search and list available wireless networks after you enable the network connection. Select your network and press **OK** to connect.

You can review or change the network settings later using the options in the Settings > Network menu. Refer to the 'Network and Connecting to the Internet' sections if you need further information. Press the **Fast Forward** button on your remote to skip.

After the internet connection is established, the TV will check for software updates and download the latest software, if available. Please note that this might take some time.

7.6 Sign In with Your Amazon Account

You can sign in to your Amazon account on the next screen. You need to be signed in to an Amazon account in order to use Amazon services. This step will be skipped if no internet connection has been established in the previous step. If you don't already have an Amazon account you can set up an account by choosing 'New to Amazon? Create an Account'. You can press the **Fast Forward** button to skip this step. A dialogue will be displayed for confirmation. Highlight 'Do this later' and press **OK** to continue. If you skip this step some of the following steps may differ or be skipped as well.

Once the account has been registered, you will be asked whether you want to use this account to sign in or change it. If you continue, you automatically accept the terms and conditions. Highlight the symbol with three dots next to the texts at the bottom side of the screen and press **OK** to read and learn more about the related subject. Highlight 'Continue' and press **OK** to proceed without changing the account.

If you have connected your TV to the internet via a WLAN network, a dialogue will be displayed, asking if you want to save your WLAN password to Amazon. Highlight 'Yes' and press **OK** to confirm and proceed. Select 'No' to proceed without confirmation.

7.7 Restore Fire TV

If you have previously used a Fire TV device, then you can choose to use the settings from that device for this TV. If you are new to Fire TV then highlight 'Skip' and press **OK**.

To restore a previous Fire TV device highlight 'Restore' and press **OK**. A list of your Fire TV devices will be displayed. Highlight the device of your choice then press **OK**. Your TV will now restore all the settings, so that they match your other Fire TV device.

7.8 Parental Controls

You can enable Parental Controls now or later in the settings.

Note that, if you choose 'No Parental Controls', purchasing and video playback will be allowed without having to input a PIN.

If you choose the 'Enable Parental Controls' option, you will be asked to enter a PIN. This is the Prime Video PIN and is related to your Amazon account. Use the buttons on your remote as

shown on the screen to enter the PIN. You will have to enter it to access some menus, services, content, and more.

If you have forgotten your PIN follow the link shown on the screen to reset it. Press **OK** to continue.

You can review or change the parental control settings later using the Parental Controls option in the Settings > Preferences menu.

7.9 Prime Video

A brief information on the prime video services will be displayed next. If eligible you can start your 30 day free trial at this point. Highlight 'Not now' and press **OK** to skip.

7.10 Welcome to Fire TV

This screen provides a brief introduction to the use of your Fire TV. After reading press **OK** to continue.

7.11 Scan for TV channels

In this step you can scan for channels. Highlight 'Yes' and press **OK** to start the scanning process. Highlight 'No' and press **OK** to scan later.

Before the scan starts, you will be asked to check if your aerial is set up and your antenna cable is plugged in properly to the antenna socket on your TV. Press **OK** to proceed.

7.12 Channel Type

Select your scanning preference to install channels for Live TV function. Terrestrial, Cable and Satellite options are available.

Terrestrial or Cable

Choose an operator in the next step, if available. You can also choose between Automatic or Manual Scan. Follow the on-screen instructions to complete the scanning process.

Note: If you have selected an operator scan you can enter data from your operator for proper channel sorting.

Satellite

Choose an operator in the next step, if available. You can also choose to perform a Manual or Complete Channel Scan. Highlight the operator option you prefer, and press **OK** to proceed. If

an operator, different than the default one is selected, a confirmation dialogue is displayed. Highlight 'Yes' and press **OK** to continue with the selected operator. The Satellite Connection screen will be displayed next. Depending on your previous selections some options may be preset automatically. Change if necessary and proceed.

If you select the **Complete Channel Scan** or **Manual Channel Scan** option, you have to select the satellite in the next step. Then the Satellite Connection screen will be displayed. Set the LNB Type, LNB Power, DiSEqC Version, Single Cable, ToneBurst, and Scan Mode options manually corresponding to your environment. When you set the DiSEqC Version option, the Port option will become available. You need to set the DiSEqC port using this option after setting the DiSEqC version.

If you select **Manual Channel Scan**, you need to additionally configure the Frequency, Polarisation, and Symbol Rate options before the scan starts.

When complete press the **Play/Pause** button. The TV will start to search available broadcasts. While the scan is ongoing, press the **OK** button to cancel. A dialogue will be displayed for confirmation. Highlight 'Yes' and press **OK** to cancel.

When the initial setup is completed, a message will be displayed on the screen. You can choose to make changes to the channel list or rescan. Highlight 'Done' and press **OK** to finish the setup. A profile selection screen will be displayed next. You can select a profile, add a new one or edit profile settings. Highlight the profile you want to continue with, and press **OK**.

Now you can see the Home screen. In order to switch to Live TV mode and watch TV channels press the **Live** button on the remote (availability depends on the model of the remote). You can also select the Terrestrial/Aerial or Satellite input option from the Inputs row in the Inputs tab on the Home screen and press **OK** to start watching.

8 Home Screen

To enjoy all benefits of your Fire TV, it must be connected to the Internet. Connect your TV to a home network with a high-speed Internet connection. You can do this either wirelessly or by using a wired connection to your modem/router. Please refer to the 'Network' and 'Connecting to the Internet' sections for detailed instructions on how to establish this connection.

The Home Screen serves as the central hub for your TV. Press the **Home** button on your remote to access it. From here, you can launch any application, switch to a TV channel, watch a movie, switch to a connected device, or manage settings. The layout of the Home Screen may vary based on your TV setup and the country selection made during the initial setup process.

The Home Screen is organized into several tabs, including Profiles, Inputs, Home, Find, Live, App Peeks, Your Apps, and Settings. You can navigate through these tabs using the directional buttons on your remote. The available tabs may differ depending on the network connection status of your TV and whether you are signed in to your Amazon account.

To explore the content within a specific tab, move the focus to the desired tab option. The options within the highlighted tab will generally be arranged in rows. Use the directional buttons to navigate through the options, select a row, and highlight the item you wish to choose. Press the **OK** button to select or to enter a sub-menu.

When you first access the Home Screen, the Home tab will open. You can use the Find tab to search for specific content. This tab features a dedicated search function that allows you to either press the Alexa Voice Button and ask Alexa to find what you're looking for or type keywords to initiate a search. The Library section displays any content you have added to your Watchlist.

9 Live TV

Live TV refers to channels that have been tuned in via a terrestrial, cable or satellite connection. There are several ways to watch Live TV channels. You can press the Live button on the remote (availability depends on the model of the remote) to switch to Live TV mode and watch TV channels. You can also select a channel from the 'On Now' row in the Home tab or select the Terrestrial/Aerial or Satellite input option from the Inputs row in the Inputs tab on the Home screen and press **OK** to start watching.

If the channel installation is not completed or the TV is NOT connected to a network with internet access, the 'On Now' row will not be available.

10 Customizing TV Settings

10.1 Picture Settings

Access the picture settings menu via the Settings menu on the Home Screen or by pressing and holding the **Home** button for approximately 2 seconds while viewing any input.

Accessing Picture Settings via Settings Menu

Press the **Home** button and scroll to the Settings tab. Scroll to 'Display & Audio' and press **OK**. Highlight 'Picture Settings' and press **OK**. Scroll down to select the input that you want to adjust the picture setting of, and press **OK**. The TV will now change to the selected input. The Picture Settings menu will appear on the right-hand side of the screen.

Accessing Picture Settings while watching TV

While watching the input that you would like to adjust press and hold the **Home** button for 2 seconds. The quick settings menu will appear on the right-hand side of the screen. Scroll down and highlight 'Picture' then press **OK**. The picture setting options will appear on the right-hand side of the screen.

10.2 Picture Menu Content

The following options show all available picture setting adjustments on your TV.

Picture settings are input specific, and all of these settings will not apply to all Inputs. Some options may not be available depending on the input source.

- **Picture Mode:** Set the picture mode to suit your preference or requirements. Picture mode can be set to one of these options: Standard, Film, Dynamic, Sport, Game, PC and Customized.
- **Backlight:** Adapt the backlight.
- **Dynamic Backlight:** Set the backlight to Off, On or Eco mode.
- **Color Saturation:** Color Saturation refers to the intensity or vividness of a color in an image or video. It determines how "pure" a color appears. When color saturation is high, the colors look bright, bold, and intense. When saturation is low, colors become more muted or washed-out, appearing closer to shades of gray. The range is from 0-100.
- **Screen Settings:** The picture format can be set to Automatic, 16:9, 4:3

Advanced Settings

- **Brightness:** Adjust the picture brightness. The range is from 0-100.
- **Contrast:** Contrast refers to the difference in brightness or luminance between the light and dark areas of an image or video. It defines how sharply different elements, such as light and dark regions, stand out against each other. The range is from 0-100.
- **Dynamic Contrast:** Set the contrast to On/Off.
- **Local Contrast:** Each frame is divided into small regions and independent contrast curves are applied for every distinct region. Local Contrast Control has 4 different settings: Off, Low, Medium, High.
- **Gamma:** Choose from Middle, Bright (standard) or Dark (film).
- **Tint:** Adjust the picture tint from -50 (reds) to +50 (greens).
- **Sharpness:** Adjust the level of crispness in the edges between light and dark areas of the picture. The range is from 0-100.
- **MPEG NR:** MPEG Noise Reduction (MNR) is a video processing feature designed to reduce or eliminate noise (visual distortion) from compressed video streams, such as those encoded in MPEG formats. MPEG Noise Reduction has 4 different settings: Off, Low, Medium, High.
- **Noise Reduction:** Noise Reduction is a video processing technique used to minimize visual noise or distortion, such as graininess, random static, or compression artifacts, in video or images. Noise can be caused by low signal quality, analog-to-digital conversion,

or compression in digital media. Noise Reduction has 4 different settings: Off, Low, Medium, High.

- **Natural Cinema:** Enhance the viewing experience by offering a more realistic, film-like image. This feature typically adjusts the color tones, contrast, and motion handling to mimic the way movies are displayed in cinemas.

10.3 Audio Settings

Access the sound settings menu via the 'Settings' menu on the main screen or by pressing and holding the **Home** button for approximately 2 seconds while viewing any input.

Accessing Audio Settings via Settings Menu

Press the **Home** button and scroll to the Settings tab. Scroll to 'Display & Audio' and press **OK**. Scroll down to 'Sound Settings' and press the **OK** button. The sound setting options will appear on the right-hand side of the screen.

Accessing Audio Settings while watching the TV

While watching the input that you would like to adjust press and hold the **Home** button for 2 seconds. The quick settings menu will appear on the right-hand side of the screen. Scroll down and highlight 'Sound' then press **OK**. The sound setting options will appear on the right-hand side of the screen.

10.4 Audio Menu Content

The following options show all the available sound setting adjustment on your TV.

- **Dolby Mode:** Dolby Audio has preset sound settings. The default setting is Smart. The available options are Film, News, Music, Smart and Off. They are designed to give you the best sound quality for the content that you are viewing. If you select Smart this will automatically detect the content you're watching and adjust the audio settings accordingly.
- **DTS Mode:** This setting can only be accessed if Dolby Mode has been switched off. DTS Mode has 6 different settings: Standard, Music, Film, Clear Voice, Enhanced Bass and Flat. The default setting is Standard.
- **Advanced Settings:** Here you are able to switch Dialogue Clarity, TruVolume and DTS Virtual:X On or Off. Highlight the desired option and press **OK** to switch on or off. You can also configure your Balance and Equalizer settings.
 - **Dialogue Clarity:** Enhances signal clarity for clear dialogue that is audible above background sound effects.
 - **TruVolume:** Provides a consistent and comfortable volume level across content.
 - **DTS Virtual:X:** Reproduces elevated sounds and a cinematic surround sound image without surround speakers.

- **Speaker Virtualiser:** This setting will only be available if the Dolby Mode option is not set to Off. The available setting options are: Off, Surround Virtualiser and Dolby Atmos.
- **Volume Leveller:** This setting will only be available if the Dolby Mode option is not set to Off. Allows you to balance the sound levels. The available setting options are: Off, Low, Mid, and High.
- **Balance:** Adjusts the sound level from the left and right speakers and can be adjusted from -25 to +25. The default setting is 0.
- **Equalizer:** This setting can only be accessed once Dolby Mode has been switched off. Equalizer has 5 different settings: 100Hz, 500Hz, 1.5kHz, 5kHz, 10kHz. Each setting can be adjusted from -10 to +10, the default setting is 0 for all.
- **TV Speakers:** Press **OK** to switch the TV speaker On or Off.
- **Reset:** Reset all settings to the factory default.

11 Settings

If you need to change or adjust anything on your TV, you'll be able to find the required setting in the Settings menu. You can access the Settings menu from the Home Screen of the TV. Press the **Home** button and scroll to Settings. The settings menu is split into separate menus to make it easy for you to find what you're looking for.

12 Inputs

Use the Inputs menu to switch between inputs and select the Media Player if you have a USB Drive connected to the USB sockets.

12.1 Accessing the Inputs Menu

You can access the Inputs menu through the Settings menu on the Home Screen. Press the **Home** button to display the Home Screen, then scroll to 'Settings'. Use the directional buttons to highlight Inputs and press **OK**.

Alternatively, access the input options from the Inputs tab on the Home Screen.

12.2 Selecting an Input

Press the left/right directional buttons to highlight your desired input then press **OK**. Your TV will now switch to that input.

12.3 Changing an Inputs Name

The input name can be changed for HDMI inputs. Highlight the input that you want to rename and press the **Options** button. Highlight 'Change Device Name' and press **OK**. You'll now see a list of devices, highlight the one that you have connected, and press **OK**. Then select 'Next'.

If you want to set the inputs back to their original names, highlight the input, press **Option** and select 'Reset Input'.

12.4 Media Player

If you have a USB storage device plugged into the USB sockets or you have files in Gallery you can access them and display them in the Media Player.

The Media player allows you to display images or play videos and audio files.

In the Inputs menu highlight 'Media Player' and press **OK**. If this is the first time you have used the Media Player, you may be asked whether you want to allow the Gallery to access photos, media and files on your device. Gallery is the name used for your TV so highlight Allow and press **OK**.

When you open the Media Player, you can see four tabs at the top of the screen: Your Files, Videos, Images, an Audio. Underneath these tabs view options are available. Select 'View All' to view all media files from all folders. Select a specific tab to view the media files from the selected category.

Press the **Options** button, highlight 'Sort' and press **OK** to see available options to sort the files displayed on the screen.

If you have multiple images on your USB Drive, you can create a slide show using your images. Highlight the Images tab at the top of the screen then press the **Options** button. From the Options menu highlight 'Multi-select Images' and press **OK**. Now select the images that you would like to add into the slide show by highlighting each image and pressing **OK**. Once you have selected all the images press the **Play/Pause** button to start the slide show.

Once you have a slide show playing you can change the setting of the slide show. Press the **Options** button to see all available options. You can set the Album, Slide Style, Slide Speed and Shuffle options according to your preferences. Adjust the settings then press the **Play/Pause** button to view your slide show.

Supported file Video formats: MPEG, MKV, MP4, MOV, 3GP and AVI.

Supported file Picture formats: JPEG, JPG, BMP and PNG.

Supported file Music formats: MP3 and WAV.

13 Notifications

The notifications menu shows you all notifications on your TV. The notification symbol (a small bubble) will appear on the upper right corner of the gear symbol on the Home Screen to indicate that you have new notifications.

13.1 Reading Notifications

Highlight 'Notifications' in the Settings menu and press **OK**. A small number in the small bubble on the upper right corner of the Notifications option indicates how many notifications you have. All available notifications will be displayed. Scroll across and highlight the notification that you want to read, then press **OK**. The message will be displayed on the screen.

13.2 Clearing Notifications

You can clear individual notifications or clear all of them.

To clear an individual notification, highlight the notification, then press the **Options** button. In the Options menu highlight 'Dismiss' and press **OK**. The notification will be deleted.

To clear all notifications, press the **Options** button, highlight 'Dismiss All' and press **OK**. All notifications will be deleted.

13.3 Managing Notifications

For App-Store related notifications you have the option to manage them. Highlight the notification and press the **Options** button. Highlight 'Manage' and press **OK**. You will be directed to the Notifications setting option in the Settings>Applications>App-Store menu. Press **OK** to turn Off the notifications related to App-Store.

13.4 Notification Settings

In order to configure the notification settings, clear all notifications first. Press the **Options** button while the message 'No new notifications' is displayed on the screen, then highlight 'Settings' and press **OK** to see the available options. 2 options are available:

- Do Not Interrupt: Hide or show all application notification pop-ups.
- App Notifications: Block or unblock notifications from individual apps.

14 Account & Profile

The option to manage your Amazon Account settings may appear different depending on the registration status of the account. If you have registered with your Amazon Account, the option will read 'Account & Profile Settings'. Otherwise, it will read 'Amazon Account Sign In/Up'. Here you can register/deregister your account or synchronize your purchased Amazon content.

14.1 Amazon Account

If you wish to remove your Amazon Account from the TV, you will need to deregister it. This will not delete your Amazon Account; it will just remove it from this TV. After deregistering your account this will remove content from your TV and many features will not work, until a new account is registered. To deregister your Account follow these steps:

1. Highlight 'Amazon Account' and press **OK**.
2. Highlight 'Deregister' and press **OK** to deregister your account. This will take a few seconds.

Important: Deregistering an account will NOT remove all personal data. To remove all personal data you need to perform a factory reset on your TV. To do this go to Settings > Device & Software > Reset to Factory Defaults.

Once the account has been deregistered, the Sign In with Your Amazon Account screen will be displayed so you can sign in using another account.

14.2 Sync Amazon Content

If you have purchased content such as movies, these can be viewed on other devices by synchronizing your Amazon content.

Highlight 'Sync Amazon Content' and press **OK**. The word 'Synchronizing' will appear. Your purchased content will now be displayed on your other devices as well.

14.3 Prime Video

Information on where you can manage your subscriptions and transactions is displayed.

14.4 Parental Controls

Your TV has some default protections which when enabled will require a PIN code to be entered for purchases, app launches, and it will also restrict viewing of content rated Teen and above.

Parental controls are set to Off as default. Highlight 'Parental Controls' and press **OK** to switch parental controls On.

Note: You will be asked to enter a PIN to turn the parental controls On or Off. This is the Prime Video PIN and it is related to your Amazon account. If you have forgotten your PIN, follow the link shown on the screen to reset it.

14.5 Profiles

Manage the profiles associated with your account. Highlight 'Profiles' and press **OK**.

14.6 Profile Sharing

Profile sharing allows Amazon Household adults to select each other's profiles on Prime Video and Fire TV. You can change these settings here.

15 Network

The Network menu includes all settings needed for connecting your TV to the internet. All available networks are shown here. You can also configure your network here.

If you have connected your TV via an Ethernet cable or the Enable Wi-Fi/Ethernet option is set to Off, wireless networks will not be listed, and wireless network related options will not be available.

15.1 Checking Network Status

Highlight 'Network' in the Settings menu and press **OK**.

The Network menu will display the strongest 3 wireless networks your TV can find. If your TV is already connected to a network, the network name has 'Connected' written underneath it.

Highlight a network to check for the signal strength and security of the connection. With your chosen network highlighted press the **Play/Pause** button to check the connection status of your network. Press the **Back** button to exit this screen. If you want to forget the network press the **Options** button while your network is highlighted.

15.2 Seeing All Networks

If you want to search for more networks, highlight 'See All Networks' and press **OK**. You will now see a list of all the networks that your TV can find. If you scroll down to the bottom of the list, you also have the option to rescan for more networks.

15.3 Joining a Network Using the WPS Button or PIN

If you can't remember your Wi-Fi password, you can connect to it using the WPS option. This temporarily disables your router's password and allows you to connect to it without it.

Highlight your preferred WPS connection option and press **OK**, then follow the on-screen instructions.

15.4 Advanced Network Settings

If you are confident in using network settings you can manually set up a network by highlighting 'Join Other Network' and pressing **OK**. Then you can manually type in all your desired network settings using the on-screen keyboard.

If you have connected your TV via an Ethernet cable you can configure your network setting. This is a more advanced setting for users that are confident in setting up networks.

15.5 Saving your WLAN Password to your Amazon Account

By saving your Wi-Fi password to your Amazon Account, you can more easily connect other devices to the same network. However, the default setting is Off.

Highlight 'Save Wi-Fi Passwords to Amazon' and press **OK**. Your WLAN password will now be saved in your account. It can be deleted at any time by selecting Off.

15.6 Turning on your TV via LAN and WLAN

Enable devices and apps that you select to turn on your TV via LAN and WLAN. Turning this option on may increase your TV's power consumption.

If you enable the network connection this option will be enabled automatically. Highlight 'Turn on with LAN and Wi-Fi' and press **OK** to disable.

15.7 Changing Connection Status

If you did not enable the network connection during the initial set up process, you can enable it here. Or you can disable it if you have enabled it previously.

Highlight 'Enable Wi-Fi/Ethernet' and press **OK** to enable or disable the network connection. Refer to chapter '30.2 Wireless Connection' if you need more information.

15.8 Basic Wi-Fi Troubleshooting Tips

If your Fire TV is having trouble with the Wi-Fi, you can check the 'Basic Wi-Fi Troubleshooting Tips' for help.

16 Display & Audio

This menu includes all settings and adjustments for your picture and sound as well as other settings such as how your TV powers on, screen mirroring, screen saver settings and HDMI CEC device control.

Highlight 'Display & Audio' in the Settings menu and press **OK**.

16.1 Picture Settings

Picture settings can be adjusted on each input, so each input can be set to have its own picture settings. For information on adjusting each setting refer to chapter 11.1 'Picture Settings'.

For adjusting picture setting while viewing your TV, press and hold the **Home** button and select 'Picture' in the menu on the right-hand side of the screen.

16.2 Sound Settings

All sound settings can be adjusted manually. For more information on how to adjust each setting refer to chapter 11.3 'Audio Settings'.

For adjusting sound settings while viewing your TV, press and hold the **Home** button and select 'Sound' in the menu on the right-hand side of the screen.

16.3 Apple AirPlay & HomeKit

Stream from your apple devices and control content with Apple AirPlay & HomeKit.

16.4 Power Controls

Power Controls has two available options:

- **Power On:** The Power On setting allows you to choose which state you want your TV to switch on in: The last input that you were watching or the Home screen. Highlight 'Power On' and press **OK**. Highlight 'Home' or 'Last Input' and press **OK**. A checkmark will appear next to your choice.
- **Voice Commands When TV Screen is Off:** When enabled, you can give voice commands through a linked Alexa enabled device when your TV screen is off. Your TV screen will turn on to complete the voice commands. Highlight this option and press **OK**. Select 'Yes' and press **OK**.

16.5 Audio Output

The Audio Output menu has 5 options: TV Speakers, Audio output jack, Digital Audio Format, DTS DRC and Bluetooth Audio Sync.

- **TV Speakers:** Switch your TV's built-in speakers On or Off. You may wish to switch them Off if you connected a soundbar to the TV.
- **Audio output jack:** Select fixed for line output or variable for headphone output.
- **Digital Audio Format:** Depending on the type of audio device you have connected you may need to adjust the audio format that your TV outputs. Highlight 'Digital Audio Format' and press **OK**. Highlight your desired audio format PCM, Dolby Digital, Pass-through and Auto then press **OK**. The default setting is Auto.
- **DTS DRC:** Switch DTS DRC On or Off.
- **Bluetooth Audio Sync:** If you have a Bluetooth speaker or headphones connected to your TV you might need to sync the audio to your device. Selecting this option will do this for you. With your Bluetooth device connected to your TV, highlight 'Bluetooth Audio Sync' and press **OK**.

16.6 Live TV Language Preferences

Select your preferred primary or secondary audio and subtitle language for Live TV channels.

16.7 Enable Display Mirroring

Enable mobile devices to temporarily mirror their display to your TV. This is called 'Display Mirroring' or 'Miracast' on your device.

Highlight 'Enable Display Mirroring' and press **OK**. 'Display Mirroring' will be displayed. Your TV is now ready for display mirroring.

16.8 Navigation Sounds

While navigating menus and selecting items, your TV will make a sound. This can be switched On and Off here. Highlight 'Navigation Sounds' and press **OK** to switch them On or Off.

16.9 Screen Saver

When your TV is inactive for a few minutes the screen saver will activate. Pictures from the Amazon Collection will start playing automatically. You also have the option to customize your screen saver. If your TV is not connected to the internet, the 'Screen Saver' feature will not be available.

Highlight 'Screen Saver' and press **OK** to display the settings menu.

- **Current Screen Saver:** Here you can change the screen saver album so it shows your pictures.
- **Slide Style:** Change the way the pictures transition. Choose between 'Pan & Zoom' or 'Dissolve'.
- **Slide Speed:** Adjust the time taken to change pictures. Choose between Slow, Medium or Fast.
- **Start Time:** Set the time before the Screen Saver starts. Choose between 5, 10, 15 minutes or Never.
- **Date and Clock:** Switch the date and time information On or Off.
- **Display Info / Smart Captions:** Switch the picture information On or Off.
- **Alexa Hints:** Switch the Alexa hints On or Off.
- **Shuffle:** Switch this option On if you want to display pictures in a random order.

16.10 HDMI-CEC Device Control

If you have a CEC enabled device connected to your TV via a HDMI cable, this setting allows your TV remote control to also control selected functions of your connected device. For example, the Standby button on your TV remote will also switch on your CEC enabled device.

The HDMI-CEC Device Control menu has 4 options: One-Touch Play, ARC, Power Control and Remote Control Pass-Through.

- **One-Touch Play:** Use your TV as the primary source for playback. Highlight 'One-Touch Play' and press **OK**. Choose between Allow, Always Ask and Deny. Highlight your desired option then press **OK**.
- **ARC:** Use your HDMI cable connection to send audio from your TV to your soundbar or AV receiver.
- **Power Control:** Use your TV to turn On/Off connected devices.
- **Remote Control Pass-Through:** Use your TV remote to control devices from other inputs.

17 Applications

The applications menu lets you manage all your apps.

17.1 Amazon Photo Settings

Here you can change the Amazon photo app settings, you can allow others to cast photos from their Amazon Photos account to your TV, and you can also disable your account so it can't be viewed on your TV.

'Allow Guest Connections' is switched On as default, if you don't want to allow other users to cast photos from their Amazon Photo accounts you can switch this feature Off. Highlight 'Allow Guest Connections' and press **OK** to switch the feature On or Off.

If you want to stop seeing your photos from your Amazon Photos account, you can disable the feature here. Access is enabled as default. Highlight 'Access Amazon Photos' and press **OK**. Highlight 'Disable Amazon Photos' and press **OK**. Your photos will now not be displayed on your TV.

Note: Even if you disable Amazon Photos, your photos will not be deleted. They will remain in your account.

17.2 Saving Gaming Progress

In some gaming apps your progress can be saved on the cloud by Whispersync, you can switch this On or Off using the GameCircle option. Highlight 'GameCircle' and press **OK**. Highlight 'Whispersync for Games' and press **OK** to switch On or Off. The default setting is On.

17.3 App Store

This menu allows you to control your app setting such as auto updates, in-app purchases and how to open external market links.

- **Automatic Updates:** When automatic updates are enabled, the App Store will automatically update your apps to the latest versions. If the permissions of the app are changed they will not be automatically updated. You will need to review any changes before agreeing and updating. Press **OK** to switch On or Off.
- **External Market Links:** Gives you the choice of how you want external links to open. Press **OK** to see the available options: Open with the Amazon Appstore, Don't Open and Ask Before Opening. Highlight the option you prefer, and press **OK**.
- **In-App Purchases:** In some apps you have the option to make in-app purchases. Choose whether you allow them or not. Press **OK** to switch On or Off.
- **Manage My Subscriptions:** You can manage your subscriptions online. Follow the link shown on the screen.

- **Notifications:** Set to On to display notifications relating to the App Store. Press **OK** to switch On or Off.

17.4 Manage Installed Applications

Here you can manage all the apps on your TV. It will also show you the amount of available memory left on your TV. As a default setting, all apps are displayed. By clicking on 'Show', you can choose between three display options: All Applications, Internal Only or USB Only.

If you want to manage an app, highlight it and press **OK**. Pre-installed apps and apps downloaded and installed by you offer different management options.

- **Pre-installed apps:** Force stop, Clear data, and Clear cache.
- **Installed apps:** Force stop, Clear data, and Clear cache, Permissions, Launch application and Uninstall.

Note: If you uninstall an app, it will still be available for you to download and re-install again in the future.

18 Downloading and Organizing Applications

Customize your Fire TV experience by easily downloading, installing, and organizing your apps.

18.1 Downloading Apps

If you want to download an App, follow these steps:

1. **Go to the App Store:** From the Home Screen of your Fire TV, navigate to the Find tab at the top of the screen. Select 'App Store' from the available options.
2. **Search for an App:** In the App Store, you can either browse through categories or use the search function. Press and hold the **Alexa Voice** button and say the name of the app you want to download. Alternatively, use the on-screen keyboard to manually type the app's name.
3. **Select the App:** Once you find the app, highlight it and press **OK** on your remote control to view the app details.
4. **Download and Install:** Select the 'Get' or 'Download' button to start the download process. Once the app is downloaded, it will automatically install and appear in your 'Your Apps' section on the Home Screen.

18.2 Organizing Apps on the Home Screen

If you want to manage your applications on the Home Screen, follow these steps:

1. **Access Your Apps:** From the Home Screen, scroll to the 'Your Apps' section or navigate to the App Store to view your downloaded apps.
2. **Open the Full App List.** If you don't see the app on the Home Screen, scroll to the end of the 'Your Apps' row and select 'See All'. This will display a full list of installed apps.
3. **Move Apps to the Home Screen:** Highlight the app you want to move, press the **Option** button on your remote control, and select 'Move'. Use the directional buttons to place the app in your preferred position on the 'Your Apps' row or another part of the Home Screen. Once you're satisfied with the location, press **OK** to confirm.
4. **Sort Apps:** You can also sort apps by selecting the **Optio** button when viewing all your apps. Options such as 'Move to Front' are available to quickly relocate the app to a prominent position on the 'Your Apps' row.

19 Equipment Control

You can choose to connect a soundbar and audio receiver to your TV. If you set it up properly, your Voice Remote with Alexa can control the connected device no matter how you connected it to your TV. This process might take some time.

19.1 Adding a Soundbar or Audio Receiver

To add a soundbar or audio receiver to your TV, make sure the device is switched On.

Highlight 'Add Equipment' and press **OK**. Highlight either Soundbar or Receiver depending on the product that you have connected, then press **OK**.

The following example shows how to set up a soundbar:

- Select the brand of your soundbar.
- Highlight the brand then press **OK**. Make sure your soundbar is switched On and the volume is up then press **OK**.
- Press **Standby** on your remote control, wait 10 seconds then press the **Standby** button again.
- You will be asked 'Did your soundbar turn off and then back on when you pressed Standby'. If it did highlight 'Yes' and press **OK**, if it did not highlight 'No' and press **OK**. You may need to repeat this process multiple times.
- When your soundbar turns Off and On, you will be asked to press the volume up and down buttons. If your volume level adjusted as expected highlight 'Yes' and press **OK**. If not, select 'No' and continue until the volume level changes.
- Your Voice Remote with Alexa has now been setup, it will now switch your soundbar On and Off and adjust the volume level.
- From now on, when you switch your TV on, your soundbar will switch on automatically as well. The TV speakers will be automatically switched off.

19.2 Soundbar/Audio Receiver Settings

Once you have set up your soundbar or audio receiver correctly, you will see either Soundbar or Audio Receiver in the Equipment Control menu. Here you can change the settings of the added devices.

Highlight 'Soundbar' or 'Audio Receiver' and press **OK**. You will now see a list of settings.

Highlight the setting that you wish to adjust and press **OK**.

- **Increase Volume:** Set the amount the volume increases or decreases when you ask Alexa to change the volume. The default is set to +4. Press **Fast Forward** or **Rewind** to increase or decrease the increments. Press **Option** to restore the default settings.
- **Infrared Options:** You can change the IR Profile, Timing and Repetition options.
- **Power Controls:** Adjust the power On/Off settings for your soundbar or audio receiver. Choose between Power On Delay, Power Command and Power Control.
- **Fire TV Input:** Change the input, to which your soundbar or receiver will switch to when watching Fire TV.
- **Change Soundbar/Change Receiver:** If you want to change the soundbar or audio receiver that's connected to your TV, highlight 'Change Soundbar/ Change Receiver' and press **OK**. To remove the device, highlight 'Change Soundbar/Change Receiver' and press the **Option** button.

20Live TV

This menu allows you to tune in your TV, manage the channels, set up a CI card and set parental controls. Highlight 'Live TV' and press **OK**.

20.1 Tuning in your TV

If you skipped the channel scan step during the initial set up process or if you need to retune your TV follow these steps.

1. Highlight 'Channel Scan' and press **OK**. Check if your antenna cable is plugged in properly into the antenna input socket on your TV. Press **OK** to proceed.
2. Select your scanning preference to install channels.
 - a. **Cable/Terrestrial:** The TV will search for digital terrestrial or digital cable broadcasts. Select the transmission method on the next screen and press **OK** to start the search.
 - b. **Satellite:** Choose an operator in the next step, if available. You can also choose to perform a manual or a complete channel scan. Highlight the operator option you prefer and press **OK** to proceed. If an operator other than the currently set one is selected, a confirmation dialogue is displayed. Highlight 'Yes' and press **OK** to continue with the selected operator. The Satellite Connection screen will be

displayed. Depending on your previous selections some options may be preset automatically. Change if necessary and proceed.

If you select 'Complete Channel Scan' or 'Manual Channel Scan', you need to select the satellite in the next step. Then the Satellite Connection screen will be displayed. Set the LNB Type, LNB Power, DiSEqC Version, Single Cable, ToneBurst and Scan Mode options manually corresponding to your environment. If you select Manual Channel Scan, you need to configure the Frequency, Polarisation and Symbol Rate options additionally before the scan starts.

3. When complete, press the **Play/Pause** button. The TV will start to search available broadcasts.
4. You will also be asked whether you want to clear existing channels, if you have installed channels previously using the same search option. Highlight 'Yes, Clear Channels' and press **OK**. All the previously tuned in channels will be deleted. Highlight 'No, Keep Channels' and press **OK** to proceed without clearing existing channels.
5. While the search is ongoing you can press the **OK** button to cancel. A dialogue will be displayed for confirmation.
6. When the search is completed 'Channel Scan Complete' will be displayed on the screen. You can choose to make changes to the channel list or rescan. Highlight 'Done' and press **OK** to finish the setup.

20.2 Automatic Service Update

You can allow your TV to automatically scan for network operator changes when the TV enters standby mode. Press **OK** to turn this feature On and Off.

20.3 Favorite Channels

View and manage your favorite channels.

If you do not have any favorite channels, go to 'Manage Channels' to add channels. Then select the source to view the channel list. Highlight a channel and press **OK** to add this channel to your favorites.

If you have added channels to your favorites previously you can press **OK** to select the channels you want to remove from your favorites. Then press **Play/ Pause** to confirm.

20.4 Manage Channels

Manage your favorite channels and select the channels you want to display.

Highlight 'Manage Channels' and press **OK**. Select the channel type: Terrestrial Channels, Cable Channels and Satellite Channels. Available options may differ depending on the currently installed channel types.

You will now see the channel list with 3 tabs: All, Favorites and Hidden:

- **All:** Shows all channels.
- **Favorites:** Shows all channels you marked as favorite channels.
- **Hidden:** Shows all hidden channels.

In the All tab you can choose to add a channel to the favorites list by pressing **OK** or you can hide a channel by pressing **Play/Pause**.

20.5 CI Card

Access your CI Card settings and information.

20.6 Parental Controls

Restrict over-the-air films, TV shows, purchases and certain types of content.

Highlight 'Parental Controls' and press **OK**. The default setting is Off so press **OK** to switch On.

Note: You will be asked to enter a PIN to turn the parental controls On or Off. This is the Prime Video PIN and it is related to your Amazon account. If you have forgotten your PIN, follow the link shown on the screen to reset your PIN.

The first time you enable Parental Controls you'll see a brief information about the settings. Press **OK** to continue and to adjust the settings. Highlight your desired setting and press **OK**. The following settings are available:

- **Parental Controls:** Press **OK** to switch parental controls On or Off.
- **PIN-Protect Purchases:** Enter a PIN before any video, app or game purchases.
- **Prime Video Ratings:** Restrict viewing of videos based on ratings. The default setting for General and Family rating is On, for Teen, Young Adults and Mature ratings is Off. Highlight the desired rating option and press **OK** to change the setting.
Note: These settings apply to Prime Video (including Amazon Channels). Content from other service providers may have their own restriction settings.
- **Broadcast Ratings:** Use ratings to restrict the display of Live TV programs from over-the-air broadcast TV accessed directly from the Fire TV user interface. Visit third-party apps to manage settings for content accessed within those apps.
 - DVB 4 (Child) - DVB 18 (Adult)
 - All settings are switched On by default

- **PIN-Protect App Launches:** Enter a PIN before launching apps and games. This setting will not apply to the content accessed directly from the Fire TV user interface, such as from the 'Guide' or 'On Now' row.
- **PIN-Protect Amazon Photos App:** Enter a PIN before launching Amazon Photos. This setting will be ignored if you have already set 'PIN-Protect App Launches' to ON.
- **Change PIN:** Change the Prime Video PIN. First enter your current PIN, then enter your new PIN. If you have forgotten your PIN follow the link shown on the screen to reset it.

20.7 Sync Sources

Sync your Live TV sources to refresh the data on this device.

20.8 HbbTV

Enable or disable HBBTV on your TV.

21 Remotes & Bluetooth Devices

You can add an additional remote control to your TV, or you may also need to replace one if your old one got broken. Other Bluetooth devices like speakers, games controllers, mice and keyboards can also be connected via Bluetooth.

21.1 Add or View Status of Remote Controls with Alexa

Check the status of your current remote control with Alexa or add a new one. Highlight 'Voice Remotes with Alexa' and press **OK**.

21.1.1 View Remote Status

To see the status of your current voice remote highlight the remote option and look at the right-hand side of the screen. You can see the type of remote control, the battery status, the version number and its serial number.

To unpair the remote press the **Options** button while the remote option is highlighted then press **OK** to confirm. The **Options** button will have no function if only one remote is paired.

21.1.2 Add New Remote

Highlight 'Add New Remote' and press **OK**.

Your TV will start looking for available devices. Press and hold the **Home** button on the new remote control for 10 seconds. When the remote has been discovered it will appear in the list.

21.2 Adding a Bluetooth Game Controller

Bluetooth gaming controllers can be connected to your TV which can be used to enjoy all gaming apps on your TV.

Highlight 'Game Controllers' and press **OK**. Highlight 'Add New Game Controller' and press **OK** to search for new controllers.

Your TV will display the message 'Searching for Controllers' on the right-hand side of the screen. Double check that your controller is discoverable and ready to pair. Follow the on-screen instructions. When the controller has been discovered it will appear in the list and can be selected.

21.3 Adding a Bluetooth Device

You can connect other Bluetooth devices such as a mouse or keyboard as well, which can be useful when using the internet browser.

Highlight 'Other Bluetooth Devices' and press **OK**.

Double check that your Bluetooth device is in pairing mode, highlight 'Add Bluetooth Devices' and press **OK**. Your device will appear in the list. Note: This could take a few minutes. Highlight the device and press **OK** to connect to it.

22 Alexa

This menu offers more information about the Alexa app and examples of things to try.

22.1 Alexa App

To find out more information about the Alexa application and where to download it select 'Alexa app'. You will need this app if you want to let your Amazon Echo speakers control your TV. In the app you'll be able to connect all your Amazon devices.

22.2 Things to Try

Get inspired and see examples of what you can use Alexa for. Highlight 'Things to Try' and press **OK** to see a list of things to try. Highlight an item in the list and press **OK** to see more information.

23 Preferences

Adjust various settings on your TV, like parental controls, privacy and data settings and restricting access to certain content and purchases.

23.1 Parental Controls

Your TV has some default protections which when enabled will require a PIN code to be entered for purchases, app launches, and it will also restrict viewing of content rated Teen and above. Parental controls are set to Off as default.

Highlight 'Parental Controls' and press **OK** to switch parental controls On.

Note: You will be asked to enter a PIN to turn the parental controls On or Off. This is the Prime Video PIN and it is related to your Amazon account. If you have forgotten your PIN, follow the link shown on the screen to reset your PIN.

Refer to chapter 20.6 'Parental Controls' for more information.

23.2 Privacy Settings

Manage all of your TV's privacy settings. Highlight the setting that you would like to adjust and press **OK**. The following settings can be adjusted:

- **Device Usage Data:** Allows use of personal data collected by the operating system of this TV for marketing and product improvement purposes. The default setting is On (=Allow). If you highlight the feature and press **OK**, you can view more information about this feature. Use the directional buttons to read the entire text. To turn this feature Off, highlight 'Turn Off' and press **OK**.
- **Collect App and Broadcast Usage Data:** Allows Amazon to collect information relating to your use of broadcast TV content, as well as the frequency and duration of your use of third-party apps. The default setting is On (=Allow). If you highlight the feature and press **OK**, you can view more information about this feature. To turn this feature Off, highlight 'Turn Off' and press **OK**.
- **Interest-based Ads:** If you opt out of interest-based ads on your TV, apps will be instructed not to use the advertising ID to build profiles for advertising purposes or target you with interest-based ads on your TV. The advertising ID is a resettable identifier that can be used to build profiles or show you interest-based ads. The default setting is On (=Allow). To turn this feature Off, press **OK**.
- **Your Advertising ID:** Shows your Advertising ID on the right-hand side of the screen. Press the **Options** button to reset your ID. A confirmation dialogue will be displayed. Highlight 'OK' and press **OK** to reset. This option is only available if 'Interest-based Ads' is On.

23.3 Data Monitoring

Manage your data usage, by highlighting 'Data Monitoring' and pressing **OK** to switch On and adjust any settings. By default, data monitoring is OFF.

- **Data Monitoring:** Switching this feature On, allows you to monitor your data consumption. The default setting is Off.
- **Set Video Quality:** Choose the video quality on Amazon Video. The default setting is Best. Available options are Good (least amount of data used), Better and Best (most amount of data used).
- **Set Data Alert:** Set a data limit and receive on-screen alerts when consumption reaches 90% and 100% of the limit. This is just an alert and will not block data consumption.
- **Monthly Top Data Usage:** View a list of your apps' and shows' individual data usage for the monthly billing cycle specified in 'Set Data Alert'.

23.4 Notification Settings

Manage your notifications, turn Off all notification pop-ups or block/unblock notifications from specific apps.

To switch On/Off notification pop-ups, highlight 'Do Not Interrupt' and press **OK**.

To block or unblock notifications from individual apps, highlight 'App Notifications' and press **OK**. A list of apps will be displayed, where you can check which apps have notifications turned On or Off. To adjust this, highlight an app and press **OK** to switch between On and Off.

23.5 Featured Content

On the Home Screen of your Fire TV, featured content is displayed at the top of the screen. This content is recommended or highlighted. When you select this featured content, a preview of the video will automatically play. You can decide whether the video plays automatically and whether the audio is turned On or Off.

You can adjust these settings as follows: Go to Settings> Preferences> featured content and press **OK**. You will see two options: 'Allow Video Autoplay' and 'Allow Audio Autoplay'.

Highlight either 'Allow Video Autoplay' or 'Allow Audio Autoplay' and press **OK** to switch the feature On or Off. The default setting is On for both features.

- **Allow video autoplay**
 - ON: The video will automatically play.
 - OFF: A still image will be displayed, and no audio will be heard.
- **Allow audio autoplay**
 - ON: Audio will be heard when the video plays.
 - OFF: No audio will be heard when the video plays.

By default, both video and audio autoplay are on. You can turn these features Off if you prefer not to have videos play automatically or if you do not want to hear audio.

23.6 Auto Turn Off

Your TV will automatically switch off after 4 hours of inactivity. This is to help save energy in case your TV was accidentally left on. If you have been watching your TV for 4 hours without pressing any buttons, a warning will appear telling you it's about to turn off. If you wish to continue watching highlight 'OK' and press **OK**.

To switch Off this feature, highlight 'Auto Power Off' and press **OK**. Highlight 'Turn Off' and press **OK**. Your TV will now not switch off after 4 hours of inactivity.

23.7 HbbTV

Enables Hybrid Broadcast Broadband TV on your TV. Highlight 'HbbTV' and press **OK** to switch On or Off.

23.8 Time Zone

Manage how the time is displayed:

- 24 hour-format or AM/PM
- Time zone

23.9 Sync Date and Time

Your TV will automatically synchronize date and time with an internet time server. If you switch this feature Off, your TV will sync with the broadcast time. This may result in network connection and playback issues. You must restart your Fire TV if you choose to switch this feature On again. Highlight 'Sync Date And Time' and press **OK** to switch it On or Off.

23.10 Language

Choose your preferred system language, by highlighting 'Language' and pressing **OK**.

23.11 Metric Units

By default, this option is ON. Temperatures and distances will be displayed in metric units. Highlight 'Metric Units' and press **OK** to switch On or Off.

24 Sleep Timer

Set a countdown to turn off your TV automatically after a specified amount of time. This countdown can range from 5 to 240 minutes.

Highlight 'Sleep Timer' and press **OK**. Highlight the desired countdown minutes until your TV switches off and press **OK**.

A countdown will start in the bottom corner of the screen. You can also switch Off the countdown by highlighting 'Off' and pressing **OK**.

Note: The TV will switch Off once the sleep time has elapsed, no warning will be shown.

25 Device & Software

View information about your TV, and legal and compliance documents. You can also restart or reset your TV back to factory defaults.

25.1 About

View information about your TV, storage and network information, and check for any available software updates.

- **Your TV:** Displays information related to your TV.
- **Storage:** Shows the available storage space on your TV and on any external device that's connected.
- **Network:** Displays all information related to network settings.
- **Check for Updates:** Displays your current software version and when it was last updated. Press **OK** to check for any new updates.

25.2 Developer Options

Enable ADB connections over the network.

- **ADB Debugging:** Press **OK** to turn On and Off. Turn On to enable ADB connections over the network. Note that turning this feature On will allow anyone on your network to install applications from untrusted sources.
- **USB Debugging:** Press **OK** to turn On and Off. Turn On to enable ADB connections over USB for this power cycle. This option will not be available if 'ADB Debugging' is set to OFF. Note that turning this feature on will make USB accessories unavailable.
- **Install unknown apps:** If you have installed an application that requests permission to install other applications and you want to grant permission, you can do this using this option.

25.3 Legal & Compliance

View all legal and compliance notices regarding your TV.

Note: Your TV will need to be connected to the internet to access Legal & Compliance information.

25.4 Sleep

Put your TV to sleep, by highlighting 'Sleep' and pressing **OK**. Your TV will go to sleep. You can wake it up again by pressing the **Standby** or **OK** button.

25.5 Restart

If for some reason your TV is slow or locking up, you may want to restart it. This will re-boot your TV. Highlight 'Restart' then press **OK**. Confirm you want to restart by selecting 'Restart' and pressing **OK** again. Restarting the TV will only take a few seconds.

25.6 Reset to Factory Defaults

Completely resetting your TV to factory defaults will remove all personal data and downloaded content from your TV. You should do this if you sell your TV or give it to someone.

Highlight 'Reset to Factory Defaults' and press **OK**. Confirm you want to reset by selecting 'Reset' and pressing **OK** again. Your TV will reset itself to the state it left the factory. This process will take a few minutes.

26 Accessibility

Switch On/off Subtitles, Alexa Subtitles, VoiceView, Text Banner, Screen Magnifier, High-Contrast Text, Audio Description and Spoken Subtitles for Broadcast Channels.

26.1 Subtitle

Display subtitles on all video content when available. Press **OK** to switch subtitles On and see more options.

26.2 Alexa Subtitle

Display subtitles for Alexa responses when available. Press **OK** to switch subtitles On and see more options.

26.3 VoiceView

The TV will provide spoken feedback as you navigate items on the screen. Manage voice guidance settings including turning VoiceView On and Off, reading speed and volume.

26.4 Text Banner

Display text related to the focused item in a box with customizable font size, colors and more. Toggle the text banner On and Off.

26.5 Screen Magnifier

Enable the use of button combinations to magnify the screen. Only available when viewing the Home Screen or menus.

Choose between available button combinations, by highlighting the preferred one and pressing **OK**. Highlight 'Turn off Magnifier' and press **OK** to turn it Off.

You can also press and hold the **Back** and **Fast Forward** buttons to activate/deactivate the screen magnifier. Once the magnifier is activated you will see a yellow box at the top of the screen. Press **Options** and a directional button at the same time to pan around the screen.

26.6 High-Contrast Text

Change the text to black or white and add a border.

26.7 Audio Description

Control the volume of the descriptive track related to the normal track for over-the-air channels and Prime Video content. Highlight 'Audio Description' and press **OK**. Highlight the option you choose and press **OK** to set. You can set 'Over-the-Air Channels' options to Off, Low, Medium or High and the Prime Video option to On or Off.

26.8 Spoken Subtitles for Broadcast Channels

The TV will speak subtitles of supported broadcast content. Press **OK** to turn it On or Off.

27 Help

If you are struggling to understand how your TV works and you need a little help, then you should look at this menu. It will show you helpful videos and quick tips about your TV. It will also give you contact details for getting support about any issue you have.

27.1 Help Videos

Watch short videos to help you understand how to use your TV.

Note: New helpful videos will be added every time your TV updates, so the amount of content changes from time to time.

27.2 Quick Tips

View a list of quick tips that show you how to use your TV or how to solve a problem you may have encountered.

27.3 Contact Us

If you feel you need more help with your TV, select the related section where you will find details of how to get in touch with a support team.

27.4 Feedback

Highlight 'Feedback' to display information on where you can send us feedback about your TV experience.

28 Channel List

The TV stores and shows all channels in the channel list. When a TV channel is turned on in Live TV mode, program information can be displayed. Alternatively, you can press the **Live** button (availability depends on the model of the remote) to display program information. Press the Down directional button to see the channel list. You can press the Left and Right directional buttons to scroll through the list.

Use the directional buttons and the **OK** button to navigate the channel list, change channels and view additional information on programs.

Press the Down directional button twice when the channel list first appears to see the options menu. You can set the subtitle and audio preferences and access the channel guide using the

related options of this menu. Refer to chapter 29 'Channel Guide' for information on managing channels.

29 Channel Guide

Browse the event schedule of the currently installed channels in your channel list. It depends on the related broadcast whether this feature is supported or not. In order to access the channel Guide press the **Guide** button on the remote.

Use the directional buttons to navigate through the channel guide. You can use the Up/Down directional buttons to switch to the previous/next channel in the list and Right/Left directional buttons to select a desired event of the currently highlighted channel. If available, the full name, start/end time and date of the highlighted event, and brief information about it will be displayed on the screen.

29.1 Highlight & Filter

Filter channels or highlight programs that have subtitles, audio descriptions or signed options and highlight programs by genre.

Use the directional buttons to highlight 'Highlight & Filter', then press the **OK** button.

- **Filter Channels:** Choose if you want to show all channels or just your favorite channels in the guide.
- **Highlight:** Highlight channels with subtitles, audio description or that are signed.
- **Genres:** Highlight programs in the Guide that have specific genres.

29.2 Scrolling Forwards or Backwards Through the Guide Day by Day

When opening the Guide you immediately see what is playing right now. If want to scroll forward a day or more, press the **Fast Forward** button. If you want to scroll back a day or more, press the **Rewind** button.

29.3 On Screen Mini Guide

While watching Live TV, a mini guide can be displayed on the side of the screen. View information on what's coming next on the current channel or scroll across to select other channels. The mini guide is a quick way to see what's on without interrupting what you're watching.

When a TV channel is turned on in Live TV mode, program information can be displayed. Alternatively, you can press the **Live** button (availability depends on the model of the remote) to display program information. Press the Down directional button twice or press the **Live** button again and the mini guide will appear:

- **Audio & Subtitle:** Set audio and subtitle preferences.
- **Highlight:** Open 'Filter & Highlights' menu.
- **Guide:** Open the TV Guide.
- **Settings:** Adjust Audio & Subtitle settings, Red Button Apps (HBBTV) settings and set low signal strength alert preference for broadcasts.
- **Signal:** Show the signal strength and quality of the channel selected.

30 Connecting to the Internet

You can access the Internet via your TV, by connecting it to a broadband system. It is necessary to configure the network settings to enjoy a variety of streaming content and internet applications. These settings can be configured from Settings>Network menu.

30.1 Wired Connection

Connect your TV to your modem/router via an Ethernet cable. There is a LAN port on the rear side of your TV. Your TV will not automatically connect to the network. You need to enable it manually using the 'Enable Wi- Fi/Ethernet' option in the 'Network' menu. Highlight this option and press **OK** to enable.

You can check the status of the connection using the 'Ethernet Configuration' option in the 'Network' menu. Highlight this option and press the **Play/Pause** button on the remote to see the network status.

To configure your wired connection settings manually highlight 'Ethernet Configuration' and press the **OK** button. Follow the on-screen dialogues to proceed and enter the required values respectively.

If the Ethernet cable is not connected, depending on the current connection status, 'Configure Ethernet Connection' or 'Configure Network' will be available instead of 'Ethernet Configuration'.

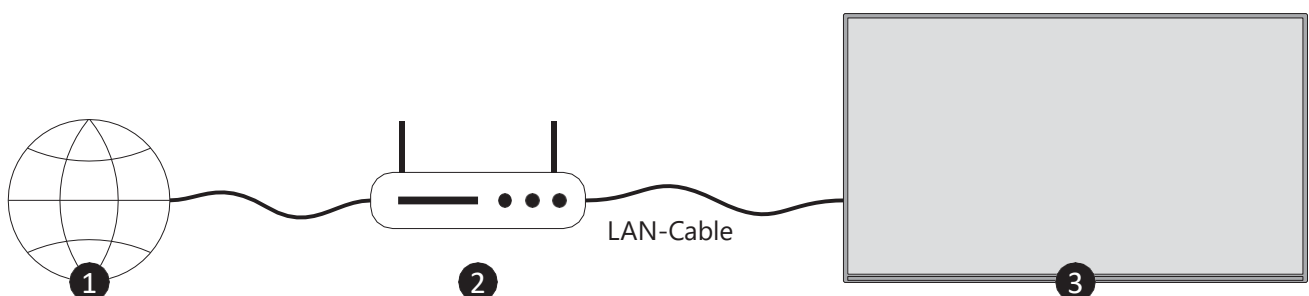

- Broadband ISP connection
- LAN (Ethernet) cable
- LAN input on the rear side of the TV

You might be able to connect your TV to a network wall socket depending on your network's configuration. In that case, you can connect your TV directly to the network using an Ethernet cable.

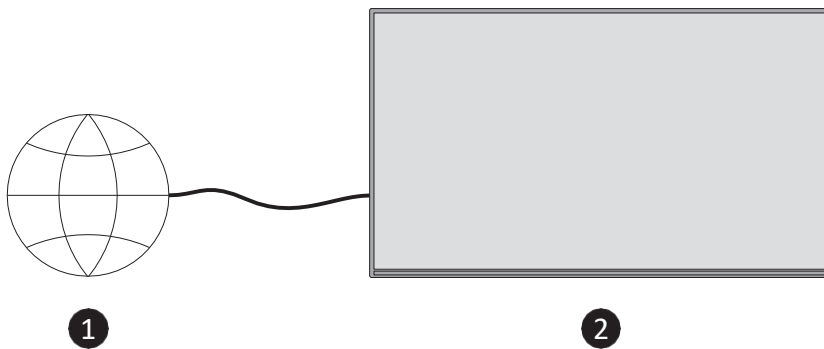

- Network wall socket
- LAN input on the rear side of the TV

30.2 Wireless Connection

A wireless LAN modem/router is required to connect the TV to the Internet via wireless LAN.

Highlight 'Enable Wi-Fi/Ethernet' option in the 'Network' menu and press **OK** to enable the wireless connection. Then disconnect the Ethernet cable, if connected previously. Some of the available networks will be listed. Highlight 'See All Networks' and press **OK** to see the complete list.

If you prefer to connect your TV to your network via WLAN you can follow one of these 3 steps.

- Highlight one of the listed available wireless networks and press **OK**. Then enter the password if the network is password protected.
- Use the WPS button on your router. Highlight 'Join Network Using WPS (Button)' and press **OK**. Press the WPS button on your router. Your TV will connect to your router, without the use of a password.

Note: During the initial setup process 'Connect using WPS Push Button' will be available instead of 'Join Network Using WPS (Button)'.

- Enter WPS PIN on your router. Highlight 'Join Network Using WPS (PIN)' and press **OK**. A code will be created and displayed on the screen. Enter this code on your router. Your TV will connect to your router, without the use of a password.

Note: During the initial setup process 'Connect using WPS PIN' will be available instead of 'Join Network Using WPS (PIN)'.

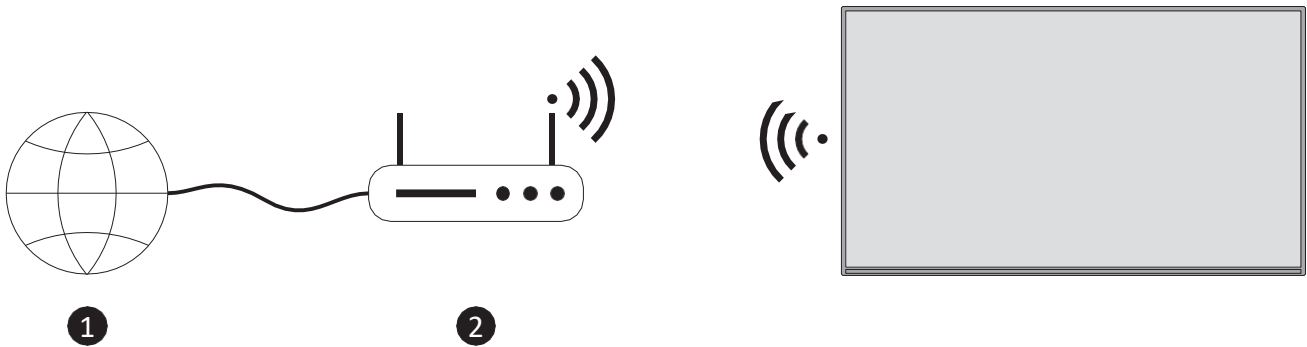

1. Broadband ISP connection

A network with hidden SSID cannot be detected by other devices. If you want to connect to a network with hidden SSID, highlight 'Join Other Network' under the 'Network' menu and press **OK**. Add the network by entering its name, security type and password manually. If you want to configure additional settings of the network manually, highlight 'Advanced' when prompted and press **OK**. Follow the on-screen instructions to proceed and enter the required values respectively.

If you want to save the wireless network passwords to Amazon you can use the 'Save Wi-Fi Passwords to Amazon' option. To delete saved passwords, turn this option Off.

A Wireless-N router (IEEE 802.11a/b/g/n/ac) with 2.4 and 5 GHz bands is designed to increase bandwidth. These are optimized for smoother and faster HD video streaming, file transfers and wireless gaming.

Use a LAN connection for quicker data transfer between other devices like computers.

The transmission speed differs depending on the distance and number of obstructions between the transmission products, the configuration of these products, the radio wave conditions, the line traffic and the products that you use. The transmission may also be cut off or may get disconnected depending on the radio wave conditions, DECT phones or any other WLAN 11b appliances. The standard values of the transmission speed are the theoretical maximum values for the wireless standards. They are not the actual speeds of data transmission.

The location where the transmission is most effective differs depending on the usage environment. The Wireless feature of the TV supports 802.11 a,b,g,n & ac type modems. It is highly recommended that you use the IEEE 802.11ac communication protocol in order to avoid any possible problems while watching videos.

You must change your modem's SSID when there are any other modems around with the same SSID. You can encounter connection problems otherwise. Use a wired connection if you experience problems with a wireless connection.

A stable connection speed is required to play back streaming content. Use an Ethernet connection if the wireless LAN speed is unstable.

31 Troubleshooting

1. Fire TV Not Turning On

Check Power Source: Ensure the Fire TV device is properly connected to a working power outlet.

Restart Device: Unplug the power cord from the Fire TV device and plug it back in after 30 seconds.

Check Remote: If the device powers on but doesn't respond, replace the batteries in the remote or try the Fire TV app to control the device.

2. Fire TV Remote Not Working

Replace Batteries: Ensure the batteries in the remote are new.

Re-pair the Remote: Press and hold the Home button on the remote for 10 seconds to re-pair it with the Fire TV device.

Restart Fire TV: Unplug the Fire TV device from power, wait a few seconds, and plug it back in.

Use the Fire TV App: Download the Amazon Fire TV Remote App on your phone as a temporary solution.

3. No Signal on TV

Check HDMI Connection: Ensure the Fire TV device is properly plugged into the TV's HDMI port.

Try a Different HDMI Port: If no signal appears, try using another HDMI port on the TV.

Switch Input Source: Make sure the correct HDMI input is selected on your TV.

Use a Different HDMI Cable: Try replacing the HDMI cable to rule out cable issues.

Check Signal from Live TV Provider: Ensure the cabling from your Live TV provider is connected securely and that there are no signal issues.

Dish TV Users: If you are watching via a satellite dish, check that the connectors are intact and that the dish is properly aligned.

DVB-T/T2 Users: If using an indoor or outdoor antenna for terrestrial TV, verify that the antenna is positioned properly and connected securely.

4. Slow Performance or Freezing

Restart Fire TV: Go to Settings > My Fire TV > Restart, or unplug and plug the power back in.

Clear Cache: Go to Settings > Applications > Manage Installed Applications, select the app that is slow, and choose Clear Cache.

Uninstall Unnecessary Apps: Remove apps that are not needed to free up system resources.

Update Software: Go to Settings > My Fire TV > About > Check for Updates to ensure the device is running the latest software version.

5. App Crashes or Won't Open

Clear Cache and Data: Go to Settings > Applications > Manage Installed Applications, select the problematic app, and choose 'Clear Cache' and 'Clear Data'.

Reinstall the App: Uninstall and then reinstall the app from the App Store.

Update the App: Ensure the app is running its latest version by checking for updates in the App Store.

6. Fire TV Not Connecting to Wi-Fi

Check Wi-Fi Network: Make sure your Wi-Fi network is working properly and other devices can connect.

Restart Router: Restart your Wi-Fi router and try reconnecting the Fire TV device.

Forget and Reconnect Wi-Fi: Go to Settings > Network, select your Wi-Fi network, and choose Forget. Then reconnect to the Wi-Fi network by entering the password.

Move Closer to Router: Make sure the Fire TV device is within a reasonable range of your Wi-Fi router for a stronger connection.

7. No Sound

Check TV Volume: Ensure the TV volume is not muted or too low.

Check Audio Settings: Go to Settings > Display & Sounds > Audio and make sure the correct audio output (e.g., Dolby Digital, Stereo) is selected.

Try Different HDMI Port: Sometimes a specific HDMI port might not be outputting audio. Switching to another port can resolve the issue.

Restart the Device: Unplug the Fire TV device, wait 30 seconds, and plug it back in.

8. Amazon Fire TV Stuck on Loading Screen

Restart the Device: Unplug the Fire TV device from power for 30 seconds, then plug it back in.

Factory Reset: If restarting doesn't work, you might need to reset the device. Press and hold the Back and Right buttons on the remote simultaneously for 10 seconds. This will trigger a factory reset.

9. Alexa Voice Commands Not Working

Check Internet Connection: Ensure that your Fire TV is connected to the internet, as Alexa relies on an active connection.

Update Alexa App: Go to Settings > Applications > Manage Installed Applications and update the Alexa app if necessary.

Re-pair the Remote: Press and hold the Home button for 10 seconds to reconnect the remote to the Fire TV.

10. Video Playback Issues (Buffering or Low Quality)

Check Internet Speed: Slow internet speeds can affect video playback. Run a speed test on another device to check your internet speed. For HD streaming, we recommend at least 5 Mbps.

Restart Device: Restart the Fire TV device to resolve temporary buffering issues.

Lower Streaming Quality: Go to Settings > Preferences > Data Monitoring > Set Video Quality, and select 'Good' or 'Better' to reduce data usage and improve playback.

Pause Other Internet Activity: If other devices are using bandwidth (e.g., downloads or streaming), pause those activities to free up more bandwidth for the Fire TV.

32 Technical specifications

	32HF2S34	40FF2S34
Digital Reception	Fully integrated digital terrestrial-cable-satellite TV (DVB-T-C-S) (DVB-T2, DVB-S2 compliant)	Fully integrated digital terrestrial-cable-satellite TV (DVB-T-C-S) (DVB-T2, DVB-S2 compliant)
Channel Indicator	On Screen Display	On Screen Display
RF Aerial Input	75 Ohm (unbalanced)	75 Ohm (unbalanced)
Operating Voltage	220-240V AC, 50/60Hz	220-240V AC, 50/60Hz
Operation temperature and operation humidity	0 °C up to 40 °C, 85% humidity max	0 °C up to 40 °C, 85% humidity max
Audio	DTS HD, DTS, VIRTUAL:X	DTS HD, DTS, VIRTUAL:X
Audio Output Power	2 x 6	2 x 8
Power Consumption (W)	47	70
Networked Standby Power Consumption (W)	<0,5	<0,5
Weight (kg)	4	6
TV Dimensions LxWxH (with stand) (mm)	728 x 175 x 467	902 x 175 x 554
TV Dimensions LxWxH (without stand) (mm)	728 x 76 x 430	902 x 87 x 517
Display	32" / 80 cm	40" / 100 cm
Screen resolution	1366 x 768	1920 x 1080

32.1 Country Restrictions

Intended for indoor use only in EU member states and EFTA states.

AT	BE	BG	CH	CY	CZ	DE	DK	EE	ES	FI	FR
GR	HR	HU	IE	IS	IT	LI	LT	LU	LV	MT	NL
NO	PL	PT	RO	SI	SK	SE	TR	UK	(NI)		

33 License

Subject to alterations. In consequence of continuous research and development technical specifications, design and appearance of products may change. Amazon, Fire, and all related marks are trademarks of Amazon.com, Inc. or its affiliates. This device is not manufactured by Amazon.com, Inc. or any Amazon affiliate. Certain services and features are subject to change or withdrawal at any time, may not be available in all areas and languages, and may require separate subscriptions. You need to be signed in to an Amazon account in order to use online services. Netflix is a registered trademark of Netflix, Inc. Netflix streaming membership required. Apple TV is a trademark of Apple Inc., registered in the U.S. and other countries and regions. Wi-Fi is a registered trademark of Wi-Fi Alliance®. The terms HDMI and HDMI High-Definition Multimedia Interface, and the HDMI logo are trademarks or registered marks of HDMI Licensing Administrator, Inc. in the United States and other countries. Manufactured under license from Dolby Laboratories. Dolby, Dolby Audio, and the double-D symbol are trademarks of Dolby Laboratories Licensing Corporation. For DTS patents, see <http://patents.dts.com>. All product names are trademarks or registered trademarks of their respective owners. ©2024 StreamView GmbH, Franz-Josefs-Kai 1, 1010 Vienna, Austria. All rights reserved. This product has been manufactured and sold under the responsibility of StreamView GmbH. THOMSON, and the THOMSON logo are trademarks used under license by StreamView GmbH – further information at www.thomson-brand.com.